



FORGE

Dedicated to the revival of the "King of Crafts"

Vancouver Island Blacksmiths

www.vibblacksmiths.com



COMING EVENTS

Oct 28- VIBA Meeting Luxford forge

Nov 25- VIBA Meeting Luxford forge

April 25-27 2008- NWBA Spring conference

Index

Executive Reports.....	2
Paper Roll holder	3,4,6-9
Show & Tell.....	5
Membership.....	10

Wayland

Wayland (Weland, Volund, Volundr) the Saxon god of metal working, although he is often seen as one of the elven race rather than a god. Wayland is the same as Volundr or Volund, who is described in Norse myth, recorded from Iceland in the form of a poem. Volundr is a smith of outstanding quality, his work is so prized that a vain king called Niduth lames him and sets him to work on an island. In revenge Volundr kills the King's two greedy sons, fashioning goblets from their skulls. He then rapes the King's daughter, and fashions wings with which he escapes from the Island. Before he flies off to Valhalla he lands on the archway of the palace and reveals the nature of his revenge to the King and his subjects. It would seem not wise to anger a smith....then or now. This revenge business can get seriously out of hand.

2007 - Executive

President: Charlie Dowdeswell
478 2460

Vice Pres.: Ray Orchard 478-9839

Secretary: Clint Montgomery 360-6910

Treasurer: Raynier Pipke 743-9945

Librarian: Skip Kennedy 478-8172

Editor: Dennis Gillett

Publishing Info: "Forge" is published monthly by and for members of the Vancouver Island Blacksmith Assoc. General Correspondence for VIBA: 1040 Marwood Ave, Victoria, BC, V9C 3C4. (or directly to appropriate executive member) Permission granted for reproduction of any part of "Forge" provided credit is given to the original source, and the item is not marked 'copyright' or specifically stated to be for the sole use of "Forge". Unless otherwise stated, the editors are the authors of all material. Disclaimer Notice: "Forge" makes every effort to ensure accuracy of the information contained therein, but the executive officers & general membership of the Vancouver Island Blacksmith Association including the editors, specifically disclaim any responsibility or liability for damages or injuries as a result of any construction design, use or application of information contained in this newsletter. The use of any information is solely at the user's own risk.

Submissions & Contributions

Submissions to "Forge" can be made at any monthly meeting or by snail mail to:

VIBA - The Editor
1040 Marwood Avenue
Victoria, BC Canada
V9C 3C4
OR
Email: dgillett@shaw.ca

President's Report

By: Charlie Dowdeswell



Presidents Report Charlie Dowdeswell September 2007

With recognition of all members past and present, a very big thank you as **VIBA** celebrates its **20th anniversary year**

Although this message is a belated one due to the FORGE publishing dates, V.I.B.A sends its sincere thoughts and best Birthday wishes to **Jim Montgomery**.

If members could bring ideas for items to be made at future 'work parties' [along with some potential dates for same] to the next meeting, that would be a good thing. We have sold all of our 'goodies, at the 'Fair/Rodeo demos and it looks like 2 or 3 work parties would be appropriate before the next season starts in the spring. Items made at home are also welcome.

While still glowing somewhat in

the aftermath of CanIRON VI and the many positive comments we have received, I believe that the true reality of what took place [at least for me] came through when we had the opportunity to read through the Newsletter published by our good neighbours from across the pond – the Northwest Blacksmiths Association. If there were any swelled heads from V.I.B.A at their October gathering this past weekend, we can put the blame on them. Back to reality with the offering of congratulations that are in order for NWBA's fine showing at CanIRON VI. Looking forward to all of our winter gatherings and will see you at the October meeting. Until then
Charlie

Note from Neil Oct 11 2007:
Jim Montgomery peacefully passed away this morning with his wife Doris, his mother Peggie Montgomery and their friend Guy at his side, at home. Jim will be cremated and the ashes will be dealt with as Jim & Doris wished.

There will be a "Celebration of LIFE" at the Nanaimo Fish & Game clubhouse on Nanaimo Lakes Rd., Saturday October 20, 2007, from 1:00 P.M. to 3:00 P.M.

If you have any stories or memories that you would like to share, Doris and the family would like you to share them with all that are present.

Jim and Doris have asked me to help coordinate and be the Master of Ceremonies for the "Celebration of LIFE".

Reprinted from the Blacksmith Guild of the Potomac July 2007

Hoffmann Publications, publishers of the Blacksmith's Journal, has given special permission for this copyrighted material to be reprinted for educational purposes, and that the use of these design ideas and published instruction is for individual use only.



PAPER ROLL HOLDER

Make this heavy duty holder to dispense any roll paper product.

Paper towels, craft paper or toilet paper are some of the products this project can be sized for (this one is made for paper towels). The frame is made from $\frac{1}{4}$ "x $1\frac{1}{4}$ " stock with one end split to make the hinge journals and spring. The other end is finished with a loop that fits inside the paper roll. A hinged bracket with another loop features an imbedded rare earth magnet that keeps it in contact with the spring when changing rolls.



A rare earth magnet passing all the way through the stock keeps the hinged bracket in contact with the spring

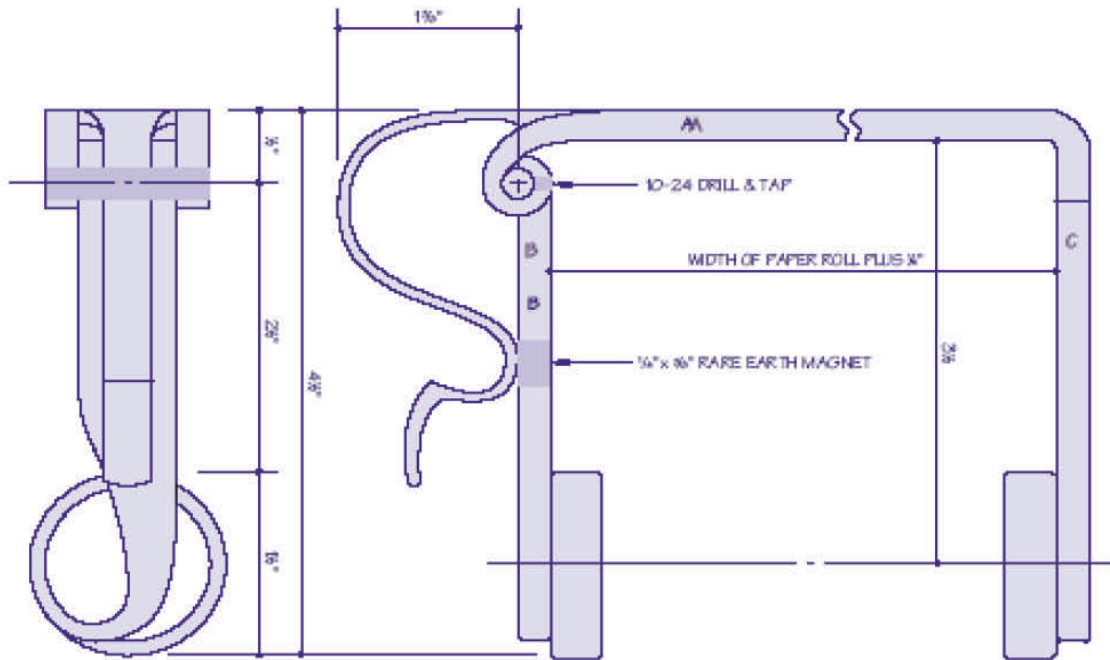

PART A

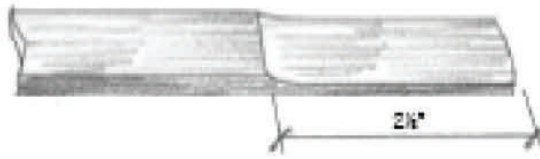

1. DRAW 3/4" x 1 1/2" STOCK DOWN TO 3/16" THICK, THEN SAW OR SPLIT TO MAKE TWO BRANCHES. TRIM THE BRANCHES SO THEY CAN BE ROLLED INTO HINGE EYES.



2. BEND THE OUTER BRANCHES BACK, AND DRAW OUT THE CENTER BRANCH TO 3/16" x 3/8" AND SHOULDER WHERE SHOWN.

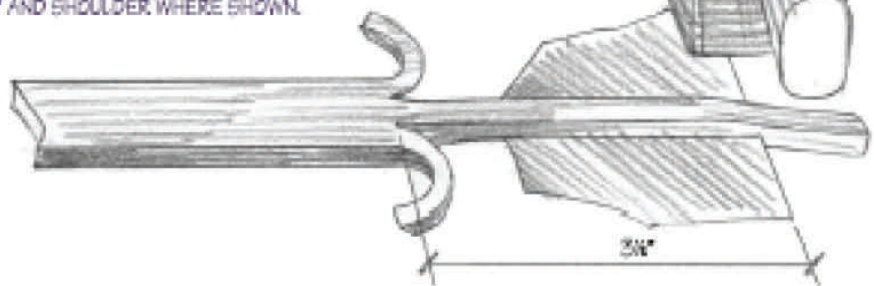

Show and Tell

Photos by Willy Tobler



Letter opener by Galen



All items made by Willy Tobler except letter opener

3. DRAW OUT THE SPRING ANOTHER INCH TO ITS FINAL THICKNESS.



4. USE SCROLL TONGS TO ROLL THE HINGE EYES

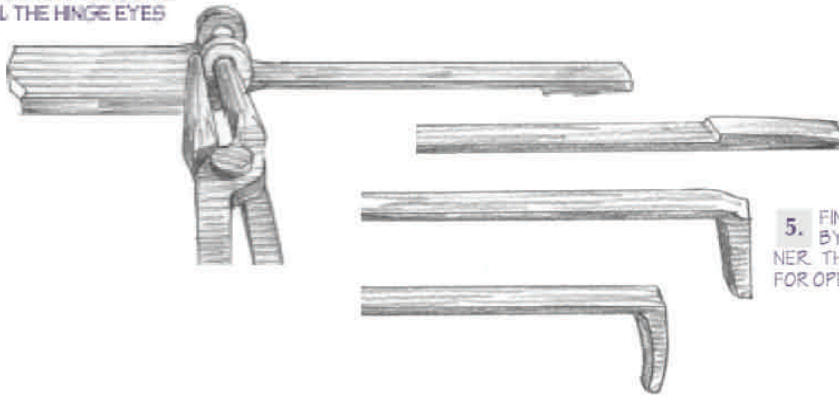

5. FINISH THE END OF THE SPRING BY MAKING A SQUARE CORNER. THIS WILL BE A THUMB LEVER FOR OPENING HOLDER.

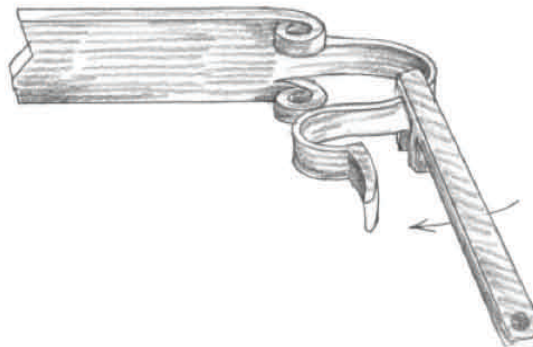

6. BEND THE SPRING TO ITS FINAL SHAPE AND HEAT TREAT AS SHOWN ON P. 2235 IF NECESSARY.

FORGED AND FABRICATED

DRAW THE END OF TWO PIECES OF 1/4" SQUARE STOCK DOWN TO 3/16" THICK AND FORM INTO EYES.



1.

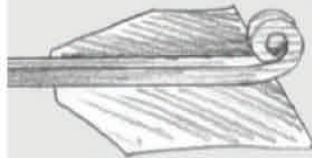

2.

DRAW THE SPRING OUT OF 1/4" x 3/4" STOCK.



If you don't need to use traditional techniques, forging, then fabricating can be quicker and easier to do. Here's how:

PART B

7. DRAW OUT THE EDGE OF $\frac{1}{4} \times \frac{3}{4}$ " STOCK TO $\frac{1}{8} \times \frac{3}{8}$ ".

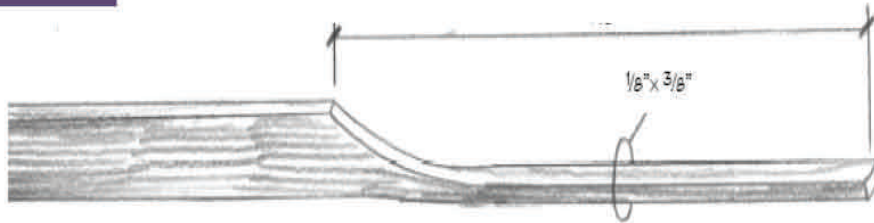

8. DRAW DOWN THE END TO $\frac{3}{16}$ " THICK.



9. FORM THE HINGE EYE.



FORGED AND FABRICATED, CONT.

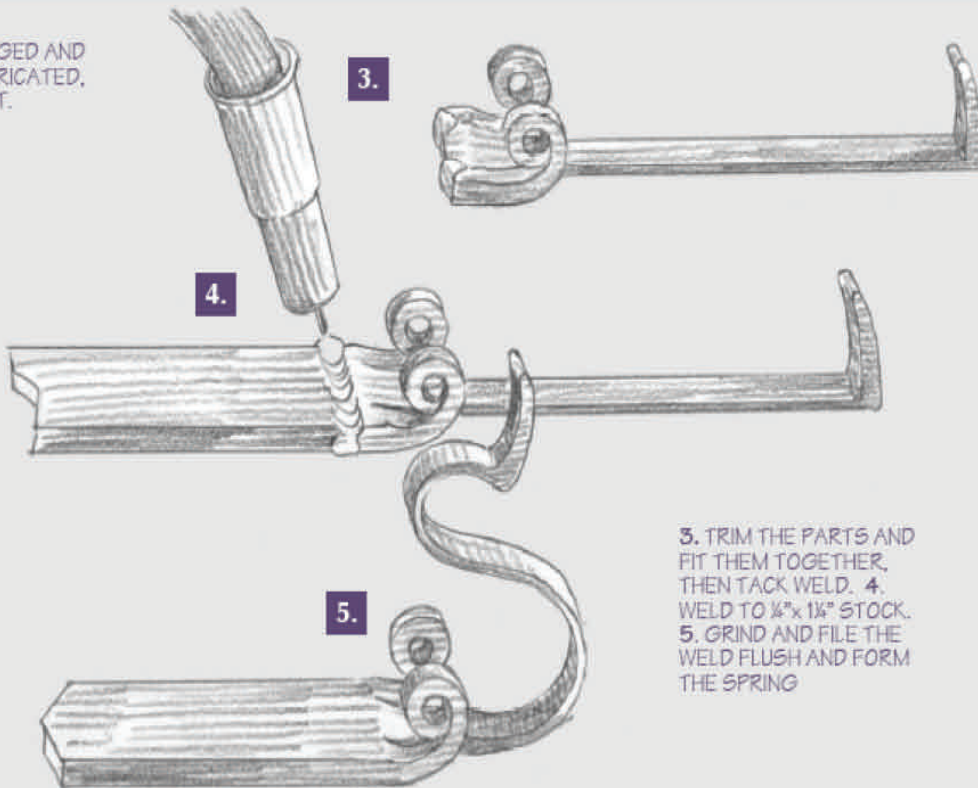

3.

4.

5.

3. TRIM THE PARTS AND FIT THEM TOGETHER, THEN TACK WELD. 4. WELD TO $\frac{1}{4} \times 1\frac{1}{2}$ " STOCK. 5. GRIND AND FILE THE WELD FLUSH AND FORM THE SPRING

10. USING A TORCH FOR HEAT, BEGIN BENDING THE DRAWN OUT PORTION INTO A RING.

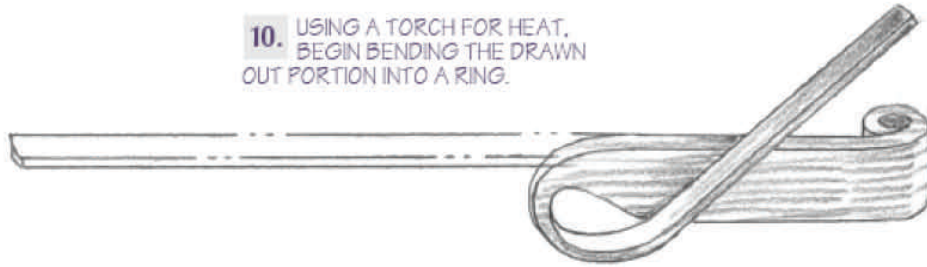

11. THE BENT RING SHOULD BE $1\frac{1}{2}$ " IN DIAMETER AND CENTERED $3\frac{7}{16}$ " FROM THE EYE.

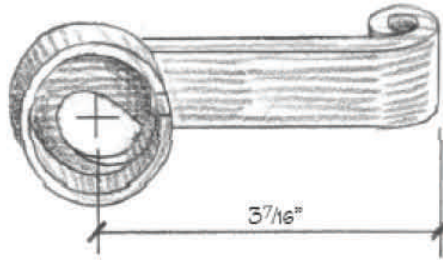

12. SAW THE RING PARALLEL TO THE PARENT STOCK TO MAKE THE COILED RING $\frac{3}{8}$ " THICK.

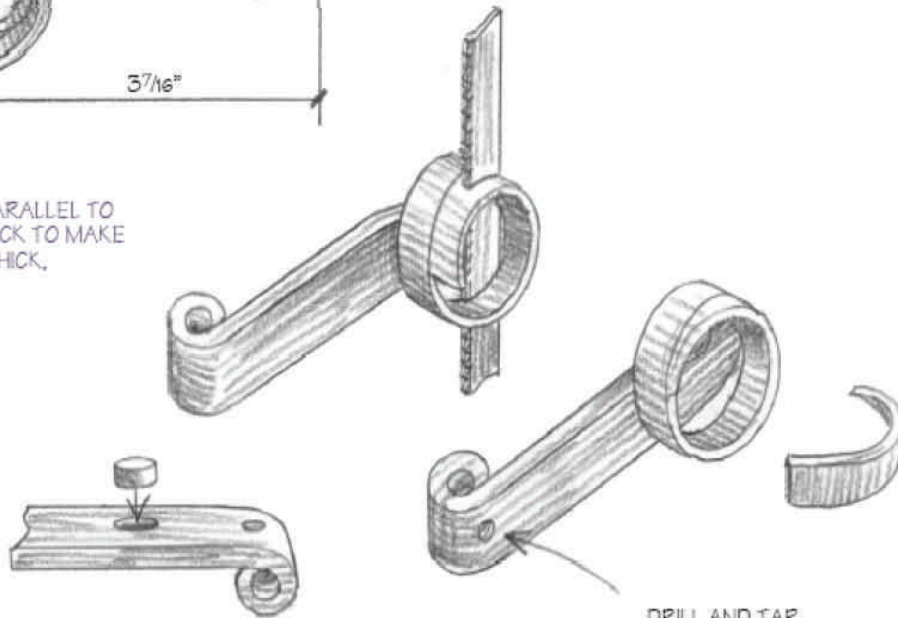

13. DRILL A $\frac{3}{8}$ " HOLE WHERE THE SPRING MEETS THE ROLL HOLDER AND PRESS FIT A $\frac{1}{4}$ " x $\frac{3}{8}$ " RARE EARTH MAGNET INTO IT.

DRILL AND TAP FOR A 10-24 SET SCREW

PART C



14. DRAW OUT $\frac{1}{4}$ " x $1\frac{1}{4}$ " STOCK TO $\frac{1}{4}$ " x $\frac{3}{4}$ ", THEN DRAW OUT ON EDGE DOWN TO $\frac{1}{8}$ " x $\frac{3}{8}$ "





15. ROLL THE END INTO A RING AND CUT IT FLUSH AS BEFORE.

16. BEND THE STOCK 90° TO FINISH PART C.

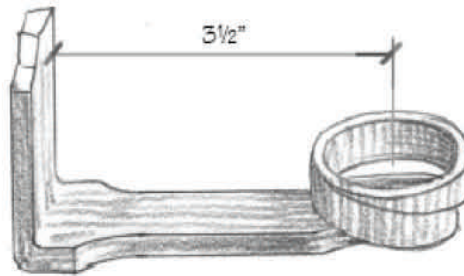

17. FIT THE TWO HALVES TOGETHER BASED ON THE WIDTH OF THE PAPER ROLL PLUS 3/16". ARC WELD OR FORGE WELD TOGETHER.

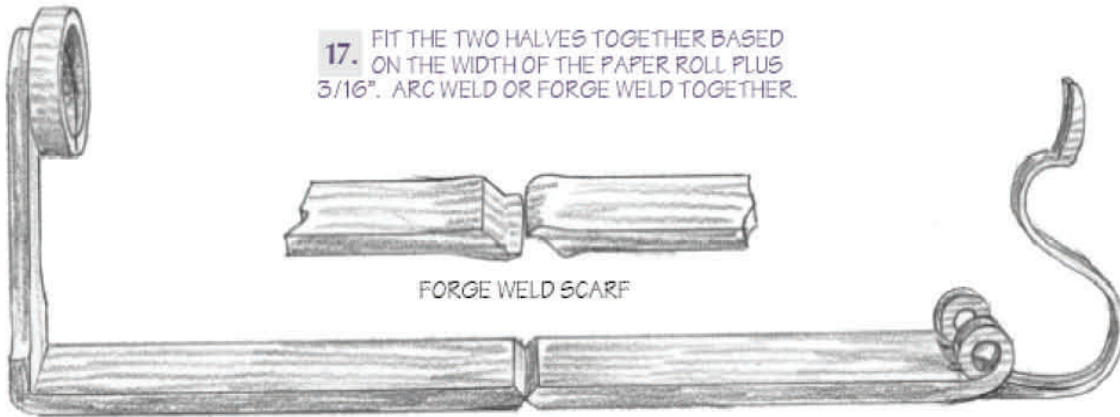

FORGE WELD SCARF

ARC WELD SCARF

18. ASSEMBLE USING A 1/4" HINGE PIN, THEN SECURE IT WITH A SET SCREW. DRILL MOUNTING HOLES TO COMPLETE.



This Feature has been provided by the Blacksmith's Journal for information about ordering call 800-944-6134 or go to www.blacksmithsjournal.com

**Vancouver Island Blacksmith Association
Membership Application**

Name: _____

Address: _____

City: _____ Prov./State: _____

Post/Zip Code: _____

Email: _____

Phone: (____) _____

Fax: (____) _____

Are you a: New Member Renewal

Regular Membership \$30.00 Annually

Contributory Member \$100.00 Annually

Members are required to sign a Liability Waiver
Make cheques or money orders payable to:

**Vancouver Island Blacksmith Assoc. (VIBA)
1040 Marwood Avenue
Victoria, BC CANADA
V9C 3C4**

**Artist Blacksmiths Assoc. of North America
Membership Application**

Name: _____

Address: _____

City: _____ State/Prov.: _____

Zip/Postal Code: _____

Phone: (____) _____

Fax: (____) _____

Full Time Student.....\$35./year

Regular Membership.....\$45./year

Senior Citizen (age 65+).....\$40./year

Overseas Surface Mail.....\$60./year

Oversea Air Mail.....\$80./year

Contributory Membership.....\$100./year

Public Library Subscription.....\$35./year

Credit Card Payment

Card No. _____

Visa Mastercard

Expiry Date: _____

Signature: _____

by Phone: (706) 310-1030

by Fax: (706) 769-7147

Mail: ABANA, P.O. Box 816,
Farmington, GA, USA. 306380816



Ron Grieg sent me an image of this stamp he received from someone joining The Western Canadian Wheelwrights after CanIRON VI. The stamp was on the application envelope. Only 13 cents... but collectors will likely pay much more.

DG